

Accelerated Knock-Outs – Typical Application

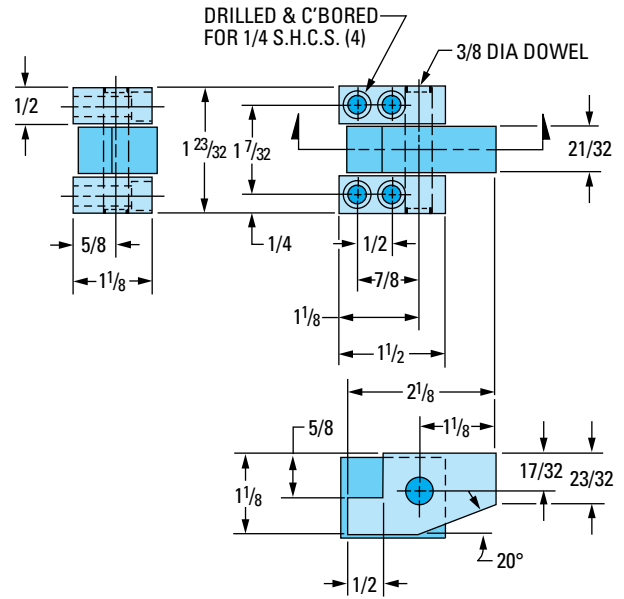
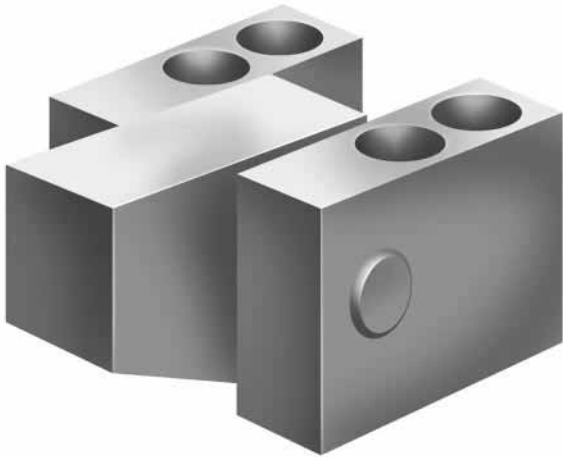

The D-M-E Accelerated Knock-Outs are simple in design, using a pivot-type motion for accelerated ejection. Mechanical advantage is 1:1. They will accommodate ejector pins up to 3/8" in diameter. (Pins with head diameters greater than 5/8" can be ground down to fit.)

Simplicity of design permits D-M-E Accelerated Knock-Outs either to be inserted into the ejector plate (as shown below) or top-mounted, depending on space available for the ejection movement.

ITEM NUMBER
AKO-1

Typical Applications

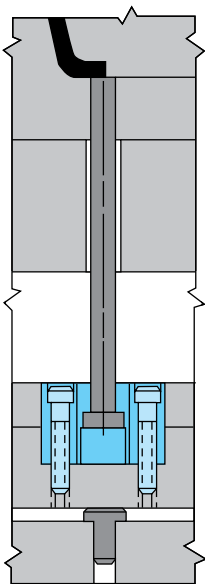

SECTION B-B
APPLICATION 1

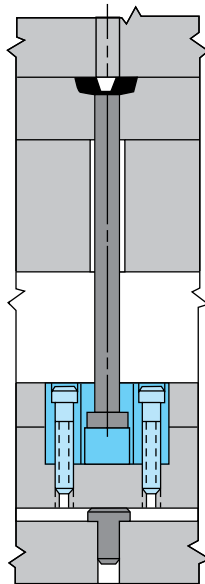

SECTION B-B
APPLICATION 2

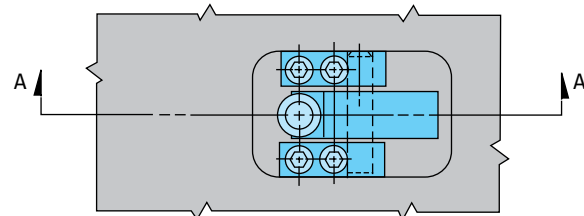

VIEW C-C

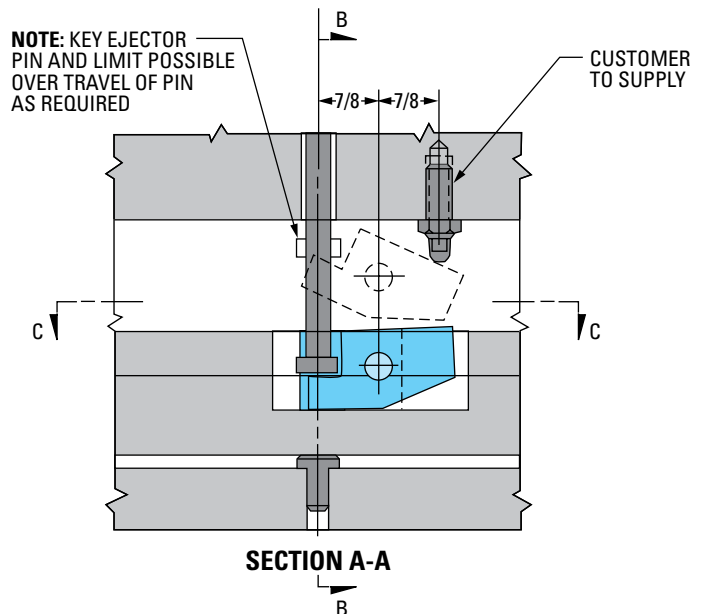

SECTION A-A